

Installation Manual

for
GSM-1000CLK GSM Intercom Systems rev 6

Fig 1

- 1) Install call point at suitable height.
- 2) GSM module to be installed in a suitable weatherproof enclosure on rear of pillar as per Fig 1.
- 3) Antenna to be mounted as high as possible for best results.

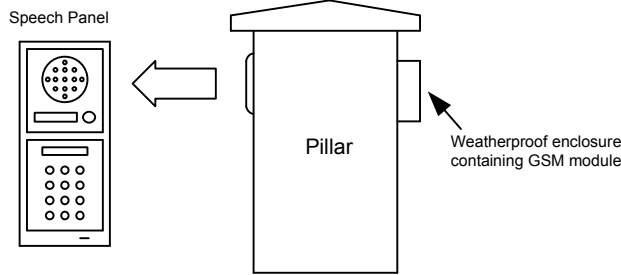

- 4) Wire call point to module as per Fig 2.
- 5) Connect power cables and wiring, carefully observing polarity.
- 5) Once fully connected, ensure power is off, and then install SIM card.
- 6) Connect power and you should now be ready for programming.

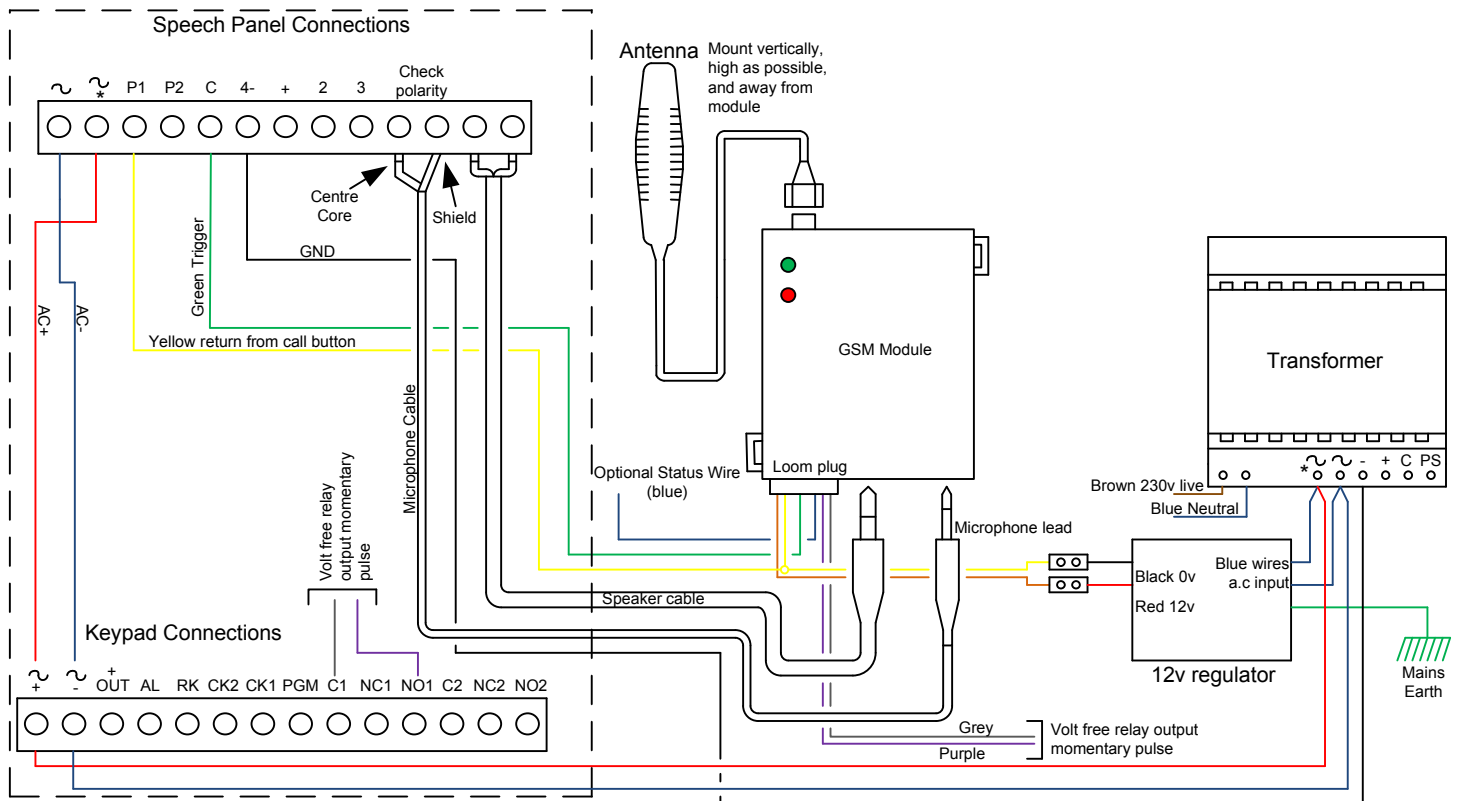

Quick Start Guide to Programming

Fig 2

- 1) Switch ON programming DIP switch 1.
- 2) Ensure DIP switch 2 is ON and for manual programming, ensure DIP switch 3 is OFF for momentary relay operation.
- 3) Ring the mobile number of the SIM card you just installed.
- 4) The unit should answer the call and respond with a long BEEP.
- 5) Clear all numbers from memory by typing the following sequence into your telephone keypad...

* 4 * * * #

- 6) If you are a trade professional or installer, you may wish to program a master user number so that changes can be made remotely without needing to visit site. This number is programmed into location 000 and is programmed by typing the following sequence into your telephone keypad..

0 0 0 * N U M B E R #

- 7) The unit will hang up. Redial the unit again. Once it answers, you may program up to 3 telephone numbers which the unit will ring when the call button is pressed. These are programmed in the same way as the master number except the memory locations to be used are 001 to 003.

0 0 1 * N U M B E R #

0 0 2 * N U M B E R #

0 0 3 * N U M B E R #

- 8) The GSM-1000 range have an access control feature built in. This allows any number stored in memory to be able to ring the unit and activate the relay. This is done by number recognition from the incoming call. Memory locations 004 to 999 facilitate this feature. Locations 001 to 003 also have this feature. These numbers are programmed in the same way as above.

0 0 4 * N U M B E R # → 9 9 9 * N U M B E R #

Note: Do NOT duplicate the engineering number in any other memory location. Do not duplicate any number, otherwise the unit may not operate correctly.

9) If there is a voicemail service or answering phone on either the first number or second number, and it picks up the call thus preventing it from dialling the next number, the system has a feature to allow adjustment of the number of rings that are made before it cancels the call and rings the next number. This can be used to avoid voicemail. You may select a value between 1 and 9. Example for 5 rings as follows..

* 8 5 #

10) Once programming is complete, switch DIP switch 1 OFF. This puts the unit into normal operating mode. Note that any further programming additions or changes can be done in 2 ways, either ring the unit from the master telephone number (if there is one stored) or switch DIP switch 1 ON and ring the unit from any number.

11) Press the call button. You should hear a voice announcement "please wait, your call will be answered shortly" and the unit will proceed to dial the first number.

12) Once the user answers the call, you can check if there is 2 way speech. The user can then trigger the relay by pressing # on their telephone keypad.

Advanced Features

* 2 # Lock the system against authorised users 004-999

* 3 # Unlock the system again

* 1 # Check the next free available memory space.

* 5 # Enter this to activate the relay when DIP 1 is on or when calling from the master number

* 6 # Optional feature used in conjunction with the status blue wire. This wire can be connected through a reed switch or limit switch to ground. This allows the user to determine the position of the door or gate when this sequence is entered. 1 bleep will be heard for one position, and 2 bleeps will be heard for the opposite position.

Description of DIP switch features

DIP Switch	ON	OFF
1	Allows programming mode from any number.	Normal operating mode. Programming only possible with engineering number.
2	Manual number storage (normally used default position)	Automatic Programming – stores any number that rings the unit automatically, used for large volumes of numbers
3	Latching relay mode (used for magnetic locks).	Momentary pulse relay mode (used for gate systems or strike locks).

Example for typical automatic gate system

